

CLIMATE

DOMETIC BREATHE AIR PURIFICATION

The latest innovation of Dometic's air purification product, the Breathe Bipolar Ionizer keeps boats smelling fresh and clean while greatly reduces allergens, viruses, bacteria and pollutants.

70 - 240VAC
POWERED DIRECT FROM BLOWER

**EASY
INSTALLATION**

**LOW
MAINTENANCE**



Mobile living made easy.

DOMETIC **OUTDOOR**

BREATHE AIR PURIFICATION

Dometic's Breathe Ion generator is the easiest way to upgrade any new or existing system to the latest in air purification technology. Two holes can be drilled anywhere in the path of moving air: in the blower housing, transition box, or directly at the discharge grille plenum. The unit can be wired directly to the fan output, so that it is only powered when needed. The wide input voltage range allows a one size fits all solution for our global customers. Power to device is simply plug and play. An LED light on top of the device clearly indicates it is functioning.

Ions travel through the air stream into the conditioned space for further air treatment. Traditional air treatment systems are only effective on the air in contact with the light as it passes through the device. Ionizers also provide a significant power savings over traditional air treatment systems.

Ionizers purify air through several methods. First, Positive and Negative Ions also help reduce pathogens, odors, and mold. Bacteria and virus cells are robbed of their life-sustaining hydrogen, reducing their number. Secondly, Odors are reduced when they oxidize on contact with the charged ions. These ions also reduce Volatile Organic Compounds (VOC) by breaking down their molecular structure. Lastly our ionizer creates both positive and negative ions which attach to the particles in the air. These attractive forces make particles effectively bigger and increases the capture rate of the air filter. This allows standard air filters to remove more particles from the air.



Benefits of Breathe

- 70VAC - 240VAC
- Reduce VOC, Allergens and Mold
- Drill and install
- No harsh chemicals
- Proven technology used in clean rooms and hospitals
- Simplistic installation - Plug provides a simple solution for installing the brushes
- Fan output - Can be connected directly to the fan output so unit is only powered when fan is operating
- Power Plug - Plug provides a simple solution for installing of the module
- LED Indicator - Light provides clear indication that unit is operating.
- Flexible - Can be connected to blower outlet or directly to discharge grille plenum
- Brass inserts - For secure corrosion resistant mounting

Voltage	70 - 240VDC
FLA	50mA
Height (in/mm)	1.6 / 41
Width (in/mm)	5.4 / 138
Depth (in/mm)	3.7 / 94
Weight (lb/kg)	TBD
Mount (in / mm)	5 / 127
Hole Size (in / mm)	0.18 / 4.5

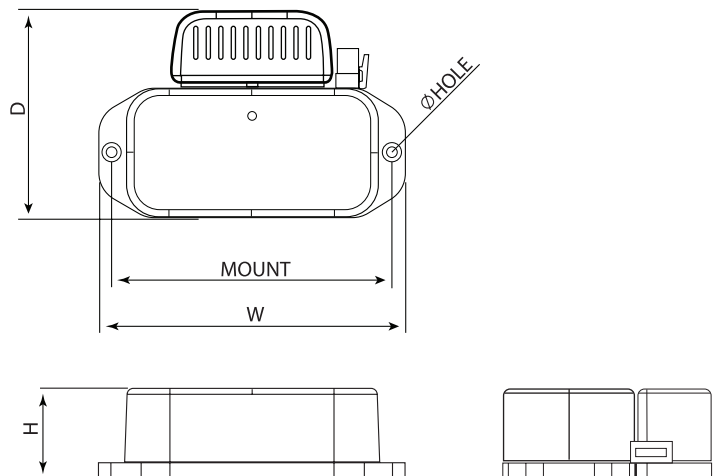

POSITIVE AND NEGATIVE ION GENERATION

The main working principle of the positive and negative ion generator is to boost the input voltage and create negative high pressure ionized air (mainly oxygen). This generates a large amount of positive and negative ions. Simultaneous generation of ions in the air neutralize the positive and negative charges to generate a huge energy release, resulting in changes in the surrounding bacterial structure.

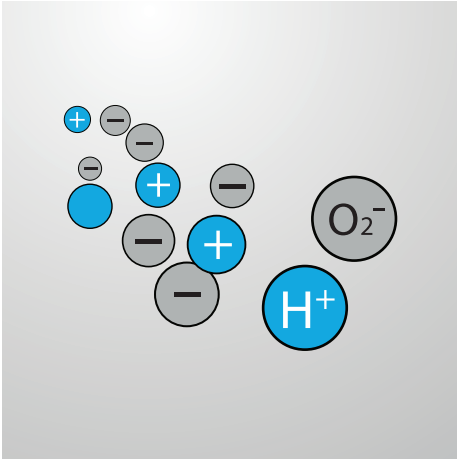

1. Ions are dispersed into the air

Positive and negative ions are created using water vapor in the air.

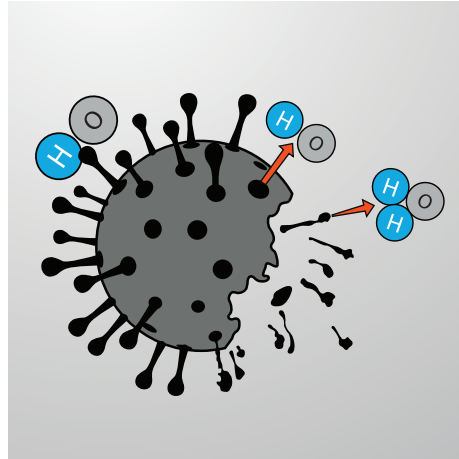

2. Attach to pollutants

The ions neutralize their charge by pulling apart airborne pollutants, thereby reducing the pollutants in the air.

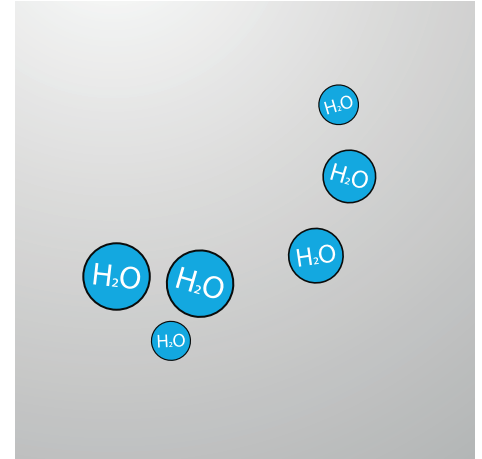

3. Ions return to the air

After neutralizing pollutants, ions are converted to water vapor.

Since the number of negative ions is larger than the number of positive ions, the excess negative ions are still floating in the air, which can achieve smoke prevention, dust removal, odor elimination, and improvement of air quality.

2023

PRESS RELEASE

Dometic launches an innovative add-on kit that easily purifies air inside the cabin

Düsseldorf, Germany – August 25, 2023

Dometic launches an innovative accessory for rooftop air conditioners that easily purifies the air onboard, providing a more comfortable and healthier cabin environment. Using state-of-the-art ionization technology, the Dometic Breathe air purifier effectively reduces dust particles, bacteria, mold build-up and unpleasant odors to secure enjoyable RV experiences.

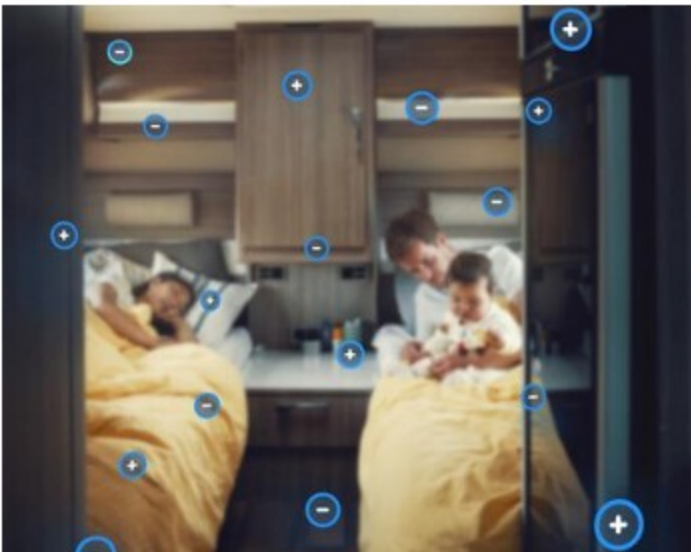

Dometic's new Breathe Ionizer is a quick and innovative way to add air purification to any RV. This affordable, easy-to-install and easy-to-use rooftop air conditioning add-on kit is now available for RV owners in Europe.

The Dometic Breathe air purifier was developed to solve a common problem faced by RV owners around the world. Time on the road is supposed to be about enjoying fresh air and sunshine outdoors, yet the air inside RV compartments can be stale and smelly. Mold, mildew, and a host of other pollutants/allergens often create bad odors and impact the ability to fully enjoy time inside.

Dometic's Breathe air purifier uses positively and negatively charged ions to reduce pathogens and mold spores by attacking their core structure. Both odors and Volatile Organic Compounds (VOCs) are reduced as ions break them down on a molecular level.



Dometic's new system also removes allergens and dust from the air. As ions in the air are attracted to particles, their size is increased. This allows them to be easily caught in the filters or causes them to fall out of the air.

This is a simpler, less expensive alternative to air purifiers using traditional technology like HEPA Filters and UV light.

Dometic's Breathe is designed as an easy and universal add on kit to a wide range of Dometic rooftop air-conditioning systems. RV owners just need to mount this device to its installed roof top air conditioner — and they are ready to breathe purified, odor-free air.

 **DOMETIC**



2023

PRESS RELEASE

The Dometic Breathe is pre-installed in the latest RV air conditioner range, the FreshJet FJX series (from Dometic, except FJX4 1500).

[End]

Note to Editors

- Dometic [press kit](#) – Caravan Salon 2023.
- Photos are available [here](#)
- More information about [the product](#)
- Dometic show catalogue – [Caravan Salon 2023](#)

About Dometic

Dometic is a global market leader in the mobile living industry. Millions of people around the world use Dometic products in outdoor, residential, and professional applications. Our motivation is to create smart, sustainable, and reliable products with outstanding design for an outdoor and mobile lifestyle in the areas of Food & Beverage, Climate, Power & Control, and Other Applications. Dometic employs approximately 8,500 people worldwide, had net sales of SEK billion (USD billion) in 2022 and is headquartered in Stockholm, Sweden.

For more information on Dometic, please visit:

<http://www.dometic.com>.

PRESS CONTACT

Minako Nakatsuma Olofzon

pr@dometic.com

+46 8 501 025 41